

4  
NEXT ASSEMBLY

WIRES CONNECTED TO CONTROL PANEL: 2, 3C, 3S  
SHIELDED: X1, X2, X3

WIRES GOING INTO VFD MUST BE SHIELDED

REVISION	ZONE	DESCRIPTION	DATE	DRWN	APVD
SHT 2	SHT 1				
B	-	DRR-1542	JUN. 1, 07	JM	-
C	-	DRR-1712	OCT. 27, 08	JM	-
D	A4	DRR-1736	FEB. 3, 09	KP	-

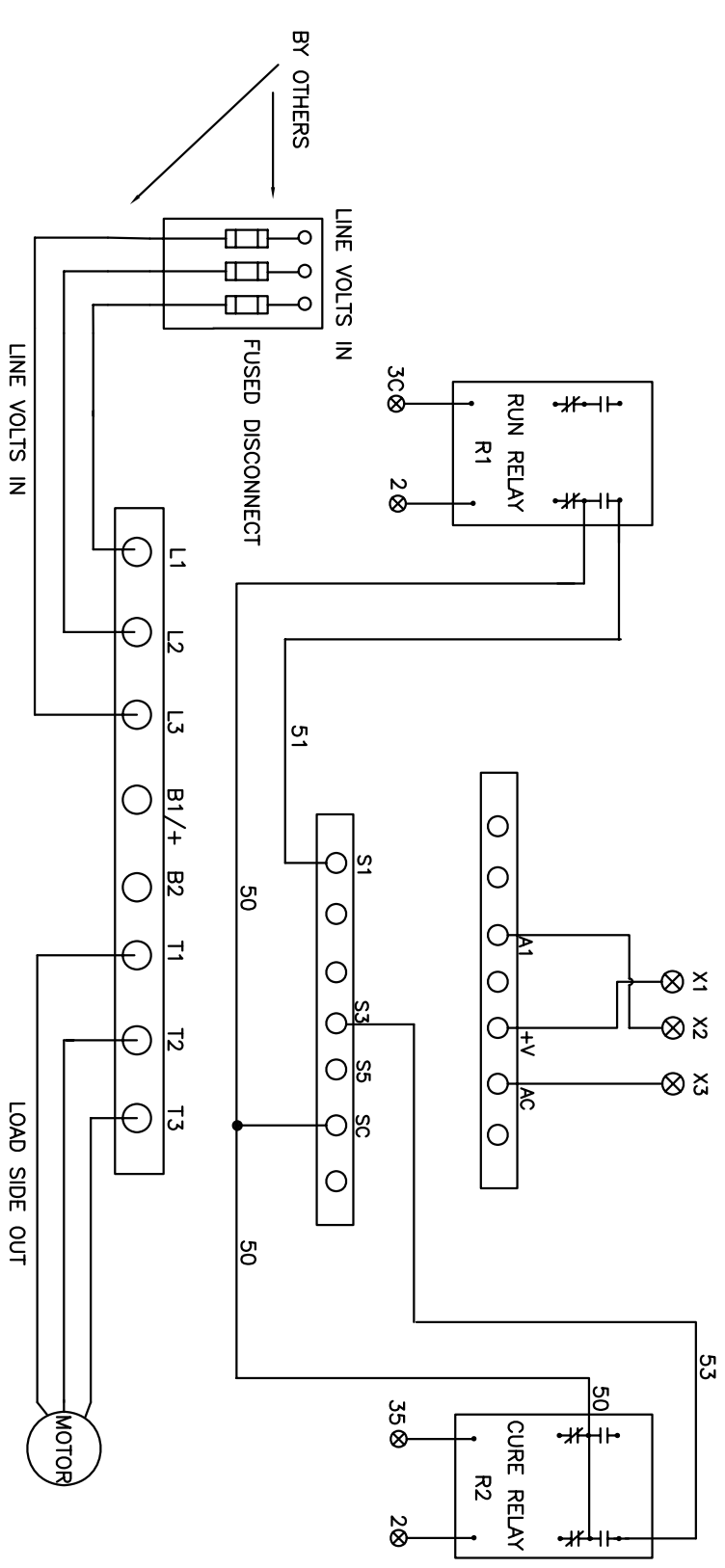

PROGRAM PARAMETERS  
 b1-01=1 WITH REMOTE POT  
 b1-01=0 WITHOUT REMOTE POT  
 c1-01=7.0 SPRAY ACCEL TIME (SEC)  
 c1-02=7.0 SPRAY DECEL TIME (SEC)  
 c1-03=10.0 CURE ACCEL TIME (SEC)  
 c1-04=100 CURE DECEL TIME (SEC)  
 d1-01=60 FREQUENCY REFERENCE  
 E1-05=MOTOR NAME PLATE VOLTS  
 E2-01=MOTOR FULL LOAD AMPS  
 H1-03=7, H1-05=6, L2-01=1, L5-01=5

DESIGNED BY/DATE: J. MEECK FEB. 5, 07	DRAWN BY/DATE: J. MEECK FEB. 5, 07	TITLES: INTERSTATE MARKETING CORP.
THICKNESS AS NOTED	REVIEWED BY/DATE:	SCALE: C
3 DECIMAL PLACES ±.015	APPROVED BY/DATE:	SIZE: 7.5HP OR LESS
ANGLES 31°		DWG NUMBER: 06186
FINISH: -		LOCATION: B/FLO
		SHEET: 1 OF 1