

TESTED TO ANSI Z83.4 & Z83.18
 MAXITROL TEMPERATURE CONTROL SYSTEM
 ELECTRONIC FLAME SUPERVISION
 FACTORY TESTED
 16 GAUGE CRS CASING
 (2) 20" DWI FORWARD CURVED BLOWER
 UNIT MTD CONTROL MODULE
 LUBRICATED BEARINGS W/ ZIRK FITTINGS
 BELT GUARD (PER OSHA STANDARDS)
 AIR PROVING SWITCH
 AIR INLET SCREEN (OUTDOOR UNITS ONLY)
 INDUSTRIAL ENAMEL EXTERIOR FINISH
 HEAT & RUST RESISTANT INTERIOR FINISH
 ADJUSTABLE BURNER PROFILE DAMPERS
 MIDCO BURNER

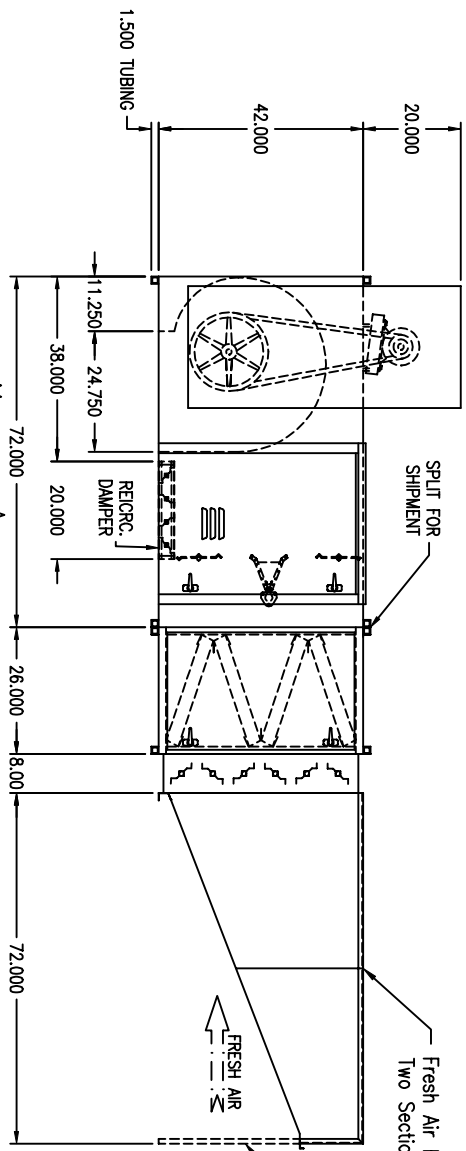

Fresh Air Hood is Shipped in Two Sections, For Shipping Reasons.

SUPPORT FOR FRESH AIR HOOD, MUST BE PROVIDED. (SUPPORT BY OTHERS)

IF CURB IS REQUIRED:
 2" x 2" CURB ANGLE WILL BE ADDED TO 1.5" BASE TUBE OF UNIT

PRELIMINARY

- NOTE:
- 1.) DRAWING IS NOT TO SCALE.
 - 2.) THIS SUBMITTAL ONLY APPLICABLE TO DIRECT FIRED BURNER.
 - 3.) DUE TO SHIPPING REQUIREMENTS, SOME ELECTRICAL RECONNECTION MAY BE REQUIRED.

WEATHER-RITE
 HEATING AND VENTILATION, INC.