

- NOTE:
 1.) DRAWING IS NOT TO SCALE.
 2.) THIS SUBMITTAL ONLY APPLICABLE TO DIRECT FIRED BURNER.
 3.) DUE TO SHIPPING REQUIREMENTS, SOME ELECTRICAL RECONNECTION MAY BE REQUIRED.

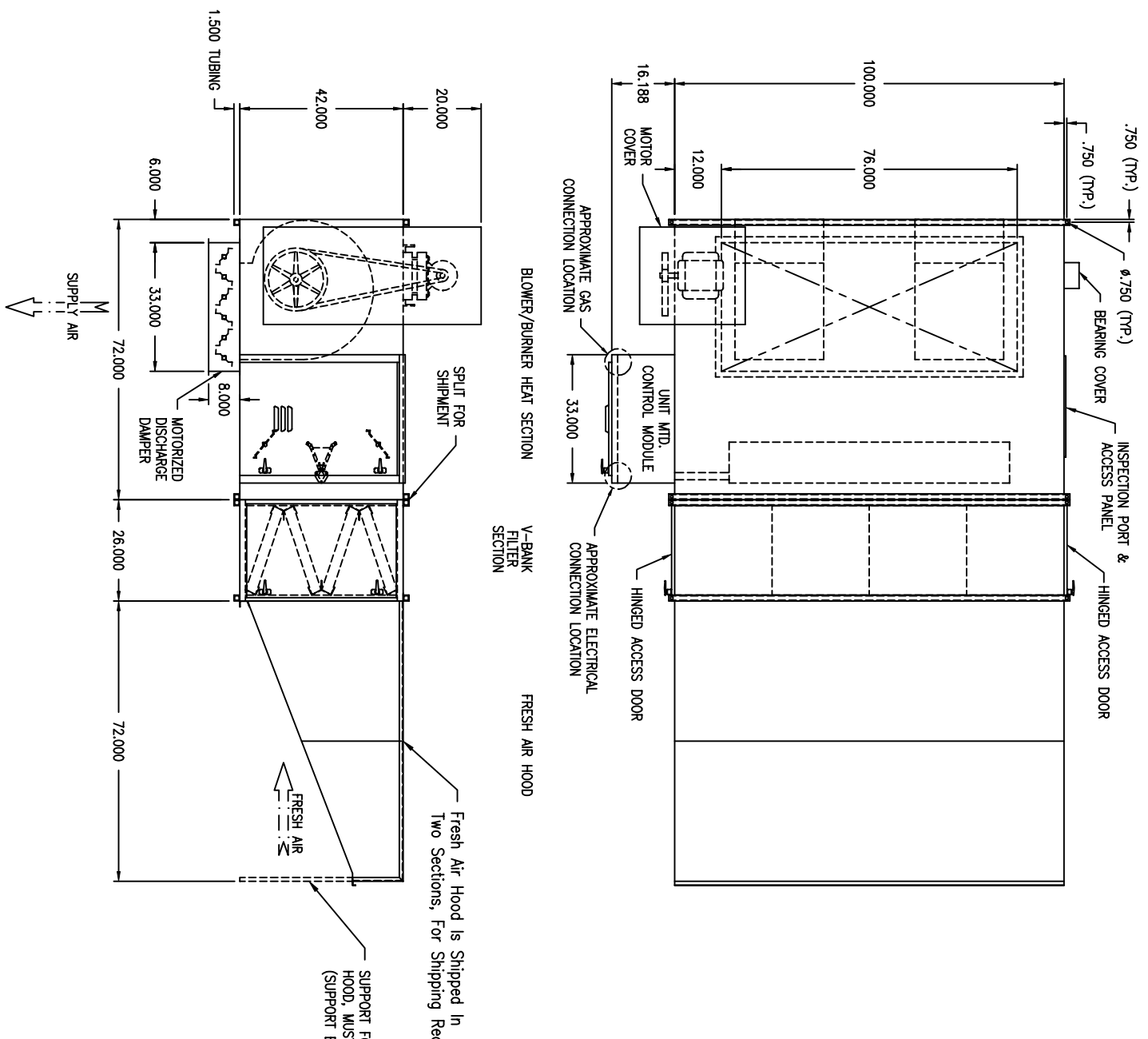

MODEL
 AirRite TT Series 221 HBL Outdoor

STANDARD FEATURES

- TESTED TO ANSI Z83.4 & Z83.18
- MAXITROL TEMPERATURE CONTROL SYSTEM
- ELECTRONIC FLAME SUPERVISION
- FACTORY TESTED
- 16 GAUGE CRS CASING
- (2) 20" DWI FORWARD CURVED BLOWER
- UNIT MTD CONTROL MODULE
- LUBRICATED BEARINGS W/ ZIRK FITTINGS
- BELT GUARD (PER OSHA STANDARDS)
- AIR PROVING SWITCH
- AIR INLET SCREEN (OUTDOOR UNITS ONLY)
- INDUSTRIAL ENAMEL EXTERIOR FINISH
- HEAT & RUST RESISTANT INTERIOR FINISH
- ADJUSTABLE BURNER PROFILE DAMPERS
- MIDCO BURNER

SUPPORT FOR FRESH AIR HOOD, MUST BE PROVIDED. (SUPPORT BY OTHERS)

IF CURB IS REQUIRED:
 2" x 2" CURB ANGLE WILL BE ADDED TO 1.5" BASE TUBE OF UNIT

PRELIMINARY

WEATHER-RITE
 HEATING AND VENTILATION, INC.