INTELLIGENT CONTROL SYSTEM-II

SERVICE TECHNICIAN MANUAL

Rapid Engineering, Inc.
Air Management Division
May , 1998

This material contains confidential information which is proprietary to and the property of Rapid Engineering. Any unauthorized use, duplication or disclosure of this material, in whole or in part, is prohibited.

No part of this publication may be reproduced, recorded, or stored in a retrieval system, or transmitted in any form or by any means, whether electronic, mechanical, photographic or otherwise, without the written permission of Rapid Engineering.

The material in this manual is subject to change without notice.

CONTROLLER INPUTS AND OUTPUTS

■ The following are the DIGITAL INPUTS:

Input number for		Description
24 pos. board	32 pos. board	
23	31	Supply Damper Limit Switch
22	30	Fan Motor
21	29	Safety Controls
20	28	Primary/Block Valve Limit Switches
19	27	Burner Lockout
18	26	Flush Signal (optional)
17	25	Exhaust Signal (optional)
16	24	Discharge dampers open (optional)
15	23	Exhaust dampers open (optional)
14	22	Forced occupied input, 3rd party (optional)
13	21	User-defined
12	20	User-defined
11	19	User-defined
10	18	User-defined
9	17	User-defined
Any unused input	Any unused input	Clogged Filter (optional)

■ The following are DIGITAL OUTPUTS:

Output Number	Description
0	Open Outside Air Damper
1	Close Outside Air Damper
2	Flame Relay Initiate
3	Flame Relay remote reset
4	Open Supply Damper
5	Start/Stop Fan Motor
6	Cooling Stage #1
7	Open Discharge Dampers (optional)
8	Close Discharge Damper (optional)
9	Open Exhaust Dampers (optional)
10	Close Exhaust Dampers (optional)
11	User Config. Output or Underpressure control
12	Cooling Stage #2 or optional
13	Cooling Stage #3 or optional
14	Relief Output
15	Reheat Output
16	User-defined
17	User-defined
18	User-defined
19	User-defined

■ The following are the ANALOG INPUTS:

Input	Description
P1 low	Discharge Air Temperature Sensor
P1 low	Outside Air Temperature Sensor
P1 high	Space Air Temperature Sensor
P1 high	Humidity Sensor
P2 low	Space Pressure
P2 low	Outside Air Damper Position
P3 high	Outdoor Humidity Sensor
P3 high	(spare)

NOTE: See the factory wiring diagram, because some digital input and output variations will occur based on the selected options.

■ The following are ANALOG OUTPUTS to the Controller:

Output	Description
P3	Modulating Gas Valve

■ The following are the COMMUNICATIONS PORTS:

Output	Description
P5	Remote Communication Port
P6	Network Communication Port

[See Appendix B for the Controller printed circuit board layout.]

DIRECTORY SET-UP AND PROGRAM FILES

The RAPID-supplied program disk contains all of the programs necessary to run the RAPID Intelligent Controls program on either a laptop or desktop computer. It also contains some simple installation programs to make it easier to install the programs on a computer's hard drive.

To install the RAPID Intelligent Controls programs on a computer's hard drive:

1. Put the RAPID floppy disk into the computer's floppy disk drive
2. At the DOS prompt, type "A:" and then the "Enter" key. (This assumes that the floppy drive is called "A". If it's "B", type "B:")
3. Type "INSTALL" and then the "Enter" key. (This automatically copies all of the RAPID programs to the "C" drive of the computer in a directory called RAPID.)

■ After installation is complete, the hard disk should be set up with files and directory as shown below:

```
c:                4000/4000.exe

                  ----- ERRORS.SYS
                  ----- SPSPLSCH.SYS
                  ----- CONFIG.REI
                  ----- HLWMMYY.DAT
                  ----- ERMYY.LOG
```

"ICSII" DIRECTORY FILES

■ The following files are required for communicating with a Controller via a desktop (or laptop) computer:

4000.EXE	Network Program File.
ERRORS.SYS	Error Code File 310.
ERRICS.SYS	Error Code File ICSII.
SPSPLSCH.SYS	Schedule and Set point File. If this file is not present, it will be automatically created by bringing the heaters "ON LINE". If it is present, it will be updated each time an air handler is brought "ON LINE".
CONFIG.REI	Network Site-Configuration File.
HLWMMYY.DAT	Hourly Log File. This file is created automatically by the Network Program and is an hourly log of each air handler's status. The "mm" represents the month of the log, and the "yy" is the year of the log.

EXAMPLE: HL1096.DAT. This file contains an hourly log of all air handlers on the network for October, 1996. Because these

ERmmyy.LOG

files can get exceptionally large, it is recommended that they be backed up and taken off the hard disk periodically.

Error Log File. This file is created automatically by the Network Program whenever an error is reported by a Controller.Hourly Log File. The "mm" represents the month of the log, and the "yy" is the year of the log.

LOCAL LINKING TO THE CONTROLLER

- Before the laptop is connected to a Controller, the air handler should be taken "OFF-LINE" using the main Network computer. This disables communications between the Network PC and that air handler, preventing nuisance errors (during the service work) and potential crashes of the communications. After the laptop communication is complete, the air handler should be brought "ON-LINE" using the main Network computer. The setpoints and schedules should be checked to verify that they have the proper settings. The "ON-LINE" command both restores communications and downloads all current setpoint, mode and schedule information to the PC issuing the ON_LINE command.
- The Rapid Engineering Remote Interface must be used to connect the laptop to either the P5 remote communication port or the P6 network communication port on the Controller.
- To start the program, the user must start the ICSII program.

REMOTE LINKING FROM AN OFF-SITE COMPUTER

- If it is desired to access a RAPID network system from an off-site computer, both the off site computer and the Network Computer must be equipped with modems and remote communication software. RAPID has successfully used Norton PCAnywhere to perform this function. The program is very easy to install, incorporates password protection and enables complete control of the off-site computer, including file transfer (e.g., hourly logs) and full operation of the RAPID Intelligent Controls II program.

AIR HANDLER START-UP PROCEDURE

- ___ 1. Refer to and complete the Air Handler Field Start-Up document that is provided in the Service Manual.
- ___ 2. Verify the power is "Off". (Disconnect switch should be in the "Off" position.) Yellow wire indicates that voltage is still present with the disconnect in the "Off" position.
- ___ 3. Check that all connections are correct to the Controller. **It is particularly important to check input and output module and network wiring before powering the Controller.** Incorrect wiring can damage the Controller. (Refer to the Electrical Diagrams and Appendix B.)
- ___ 4. Verify that the space temperature sensor is installed and properly wired.
- ___ 5. Verify that all wiring connections between air handler sections have been properly made. (Wire #1 connected to Wire #1, etc.)
- ___ 6. Complete the steps that are listed in the General Inspection section of the Air Handler Field Start-Up document that is provided in the Service Manual for each unit.
- ___ 7. Verify that the address switch on the Controller is set for the correct address. (Each Controller has its own address on the communications network. Refer to Appendix "A" for information on setting the address.)
- ___ 8. Connect a PC to the Controller port labeled P5 or P6. The RAPID Interface kit is required when making this connection.

9. With the control enclosure door open, place the disconnect switch in the "On" position. Extreme caution is required, usually very high voltages are present within the control enclosure. Only qualified and fully trained technicians should perform the work described within this procedure.
- Initially all LED indicators on the input/output (I/O) Rack should be "Off", except that the input(s) for the Flush / Exhaust option and other monitoring inputs (if so equipped) may be on.
 - As soon as the disconnect switch is placed in the "On" position, the red and green LED's on the Controller should illuminate. When the red LED is flashing, that is an indication that the PC and heater controller are communicating successfully.
 - If the air handler is an AM, output module #0 should close driving the Outside Air Damper fully open. At the same time, if there is a separate Return Air Damper motor, the Return Air Damper will drive fully closed.
 - When the damper motors have reached their end of travel, a pause occurs and then output module #1 should close, driving the Outside Air Damper fully closed. If there is a separate Return Air Damper motor, the Return Air Damper will drive fully open.
 - At the end of this sequence, which is called "Start-up", all LED indicators on both I/O Racks should be "Off" (unless the air handler is equipped with the Flush / Exhaust option or other monitoring inputs).
 - Verify that the dampers move to their fully open and fully closed positions during the Start-up sequence.

NOTE: To satisfy start-up cycling of the damper motors, the voltage on the shielded cable that is connected to the damper motor, measured on the black conductor (or term. 7, P2 lower on the controller), with respect to the white conductor (or term. 6, P2 lower on the controller), must meet the following:

R.A. Damper full closed = greater than 4.4 VDC R.A. Damper full open = less than 0.4 VDC

- Power up your computer and start the "RAPID ICSII" program. After clicking on the Unlock Button, enter the password to Unlock the system.
 - Bring the Controller "On-Line." (Be sure to select the correct air handler address.) The LED on the Controller will be blinking when the controller is transmitting information back to the computer.
 - Return to the main screen and locate the button on the button bar that resembles an Upright air handler. Depress the button. The air handler that your PC is communicating with should appear on the monitor (status screen). The screen should indicate that the air handler is in the "OFF" mode. No errors should be detected. If an error is detected, determine the cause of the error and correct the problem. The error log will help in determining the problem. See the Error Code Guide in the Operator's Manual for more information.
 - Verify that the information displayed on the Status screen is correct. The temperatures displayed on the screen may be calibrated to measured values using the appropriate potentiometer on the Controller, if necessary. (Refer to Appendix B, Controller Circuit Board, for calibration potentiometer location. Also, refer to the Air Handler Field Start-Up document that is provided with each air handler).
 - Check the calibration of the Pressure Transducer by removing the tubing connection from the "Hi" and "Lo" input ports. Connect a digital voltmeter across the "Vout" and the "Com" terminals. The meter should read $+2.50 \text{ VDC} \pm 0.01 \text{ VDC}$. If it is necessary to adjust the voltage reading, remove the "Zero" adjustment plug and turn the trimpot with a small screwdriver. Replace the hole plug after making the adjustment. The Space Pressure reading on the Unit Status screen should be 0.0" wc. Replace the tubing on the "Hi" and "Lo" input ports.
- NOTE:** Do not adjust the "Span" on the Transducer.
- Check the Schedule and the number of the air handler being tested. Verify that the correct days and times are displayed for the Occupied Period(s). Change the schedule if necessary.
 - Check the fan rotation and correct as needed.
 - While in the Status Screen, select the number of the air handler to be tested. Change the mode of the air handler to "Manual".
 - The following sequence should occur:
 - Output module #5 illuminates and powers the Fan Motor Contactor.
 - The Fan Motor starts and input module #22 or #30 illuminates.

- If the Space Temperature is equal to or less than the Occupied Space Temperature setpoint,
 - a. Output Module #4 illuminates and powers the Supply Damper Motor to the fully open position.
 - b. After the Supply Damper is open, which is indicated when its input module (23 or 31) is illuminated.
 - c. After a short delay, the Safety Controls input module (21 or 29) illuminates indicating that the Air Flow, High Gas Pressure, Low Gas Pressure and High Temperature Limit switches are closed.
 - d. Output module #2 illuminates and initiates the Flame Relay ignition sequence.
 - e. The Flame Relay goes through its cycle of "Prepurge", "Trial for Ignition" and "Flame Safeguard Output".
 - f. The Flame Relay powers the Primary and Block Valves open.
 - g. The Block Valve limit switches prove that they have opened to their input module (20 or 28).
 - h. The voltage on the Modulating Gas Valve is set by the Controller to satisfy the Minimum Discharge, Maximum Discharge and Space Temperature requirements.

NOTE: The above mentioned sequence is true for AM, AR and VAV units only. When starting an MUA unit, expect a pause after the unit is first turned on to allow the inlet air damper (if provided) to open before the fan contactor is energized.

_____ 18. Verify that the low and high fire flames are appropriate.

- Before the flame calibration procedure, connect a manometer at the location of the 1/4" NPT plug in the High Gas Pressure Switch piping. A 1/4" NPT-to-barb fitting is normally used to do this.
 - a. With the flame OFF and the fan ON,
 - b. read the pressure in the gas piping using the manometer.
 - c. Record the measured pressure. (Leave the manometer connected.)

This pressure is always NEGATIVE (less than zero). Shutting the main gas valve will make sure the flame is off. This may cause an error to occur, but it will not normally cause the air handler to shut down and can easily be reset.

- To force the air handler into High Fire, disconnect the space and discharge temperature sensors from the controller. This will simulate low space and discharge temperatures to the Controller, causing it to place approximately 24VDC on the Modulating Gas Valve coil, driving it fully open.

Now measure the manifold pressure with the manometer again. If the DIFFERENCE between the new manometer reading and the earlier (no flame) reading is NOT the same as indicated on the air handler nameplate, adjust the Modulating Gas Valve as described in Appendix J.

After completing any necessary calibration, reconnect the temperature sensors. **NOTE:** When the discharge temperature sensor is disconnected, a low discharge temperature is simulated. After five minutes, the Controller will record a Low Discharge Temperature error and change the air handler to the "Off" mode. Either reconnect the sensor before 5 minutes have elapsed or reset the error and reconnect the sensor.

- To force the air handler into Low Fire, disconnect either P3 on the controller or the Modulating / Regulating valve power at the valve. A proper low fire flame is approximately 1-2" long (from the throat of the burner) with NO BLANK (dark) SPOTS. If in any doubt, or the flame is not proper, adjust the Modulating Gas Valve as described in Appendix J. After completing any necessary calibration, reconnect power to the valve.

_____ 19. While in the status screen press the Setpoints Button on the Button Bar.

- a. Change the % Outside Air setpoint to 20. Verify that the Outside-Air Damper closes fully (20% ± 1%) and the Return-Air Damper opens fully (80% ± 1%) (AM and VAV units only).
- b. Change the % Outside-Air setpoint to 100. Verify that the Outside-Air Damper opens fully (100% ± 1) and the Return-Air Damper closes fully (0% ± 1%).
- c. Change the "% Outside Air" setpoint to 50%. Verify that the dampers position correctly (50% O.A., 50% R.A. ± 1%) (AM and VAV units only).

_____ 20. While in the status screen "click" on the current mode. Change the Mode of the air handler to "Auto Pressure". Verify that the dampers drive as required to maintain the "Pressure Setpoint."

_____ 21. Change the Mode of the air handler to "Off". Verify that the air handler turns off. The Supply Damper and Outside Air Damper should close (0% O.A.) and the Return Air Damper should open fully (100%) (AM and

VAV units only). All LED indicators on the I/O Rack should be "Off" (except the input modules for the Flush / Exhaust option, if the air handler is so equipped).

APPENDIX A: CONTROLLER NETWORK ADDRESSING

- Each Controller on the network must be set to a unique address as defined by the System Configuration.
- The Network Address is set by positions 1 through 7 on switch "SW1," which is located on the Controller. Position 8 on the switch should always be placed in the "Off" position.
- Each switch position has a certain numeric value when placed to the "On" position. (Each switch has twice the value of the preceding switch.)

Switch Position	1	2	3	4	5	6	7
Value	1	2	4	8	16	32	64

Example 1: Set address to 13
 Positions 4, 3, & 1 = on
 (8 + 4 + 1 = 13)

Example 2: Set address to 3
 Positions 2 & 1 = on
 (2 + 1 = 3)

Example 3: Set address to 99
 Positions 7, 6, 2 & 1 = on
 (64 + 32 + 2 + 1 = 99)

NOTE: The address must never be set above 99.

CONTROLLER NETWORK ADDRESS TABLE

Switch #	7	6	5	4	3	2	1
0	0	0	0	0	0	0	0
1	0	0	0	0	0	0	1
2	0	0	0	0	0	1	0
3	0	0	0	0	0	1	1
4	0	0	0	0	1	0	0
5	0	0	0	0	1	0	1
6	0	0	0	0	1	1	0
7	0	0	0	0	1	1	1
8	0	0	0	1	0	0	0
9	0	0	0	1	0	0	1
10	0	0	0	1	0	1	0
11	0	0	0	1	0	1	1
12	0	0	0	1	1	0	0
13	0	0	0	1	1	0	1
14	0	0	0	1	1	1	0
15	0	0	0	1	1	1	1
16	0	0	1	0	0	0	0
17	0	0	1	0	0	0	1
18	0	0	1	0	0	1	0
19	0	0	1	0	0	1	1
20	0	0	1	0	1	0	0
21	0	0	1	0	1	0	1
22	0	0	1	0	1	1	0
23	0	0	1	0	1	1	1
24	0	0	1	1	0	0	0
25	0	0	1	1	0	0	1
26	0	0	1	1	0	1	0
27	0	0	1	1	0	1	1
28	0	0	1	1	1	0	0
29	0	0	1	1	1	0	1
30	0	0	1	1	1	1	0
31	0	0	1	1	1	1	1
32	0	1	0	0	0	0	0

Switch #	7	6	5	4	3	2	1
33	0	1	0	0	0	0	1
34	0	1	0	0	0	1	0
35	0	1	0	0	0	1	1
36	0	1	0	0	1	0	0
37	0	1	0	0	1	0	1
38	0	1	0	0	1	1	0
39	0	1	0	0	1	1	1
40	0	1	0	1	0	0	0
41	0	1	0	1	0	0	1
42	0	1	0	1	0	1	0
43	0	1	0	1	0	1	1
44	0	1	0	1	1	0	0
45	0	1	0	1	1	0	1
46	0	1	0	1	1	1	0
47	0	1	0	1	1	1	1
48	0	1	1	0	0	0	0
49	0	1	1	0	0	0	1
50	0	1	1	0	0	1	0
51	0	1	1	0	0	1	1
52	0	1	1	0	1	0	0
53	0	1	1	0	1	0	1
54	0	1	1	0	1	1	0
55	0	1	1	0	1	1	1
56	0	1	1	1	0	0	0
57	0	1	1	1	0	0	1
58	0	1	1	1	0	1	0
59	0	1	1	1	0	1	1
60	0	1	1	1	1	0	0
61	0	1	1	1	1	0	1
62	0	1	1	1	1	1	0
63	0	1	1	1	1	1	1
64	1	0	0	0	0	0	0
65	1	0	0	0	0	0	1

Switch #	7	6	5	4	3	2	1
66	1	0	0	0	0	1	0
67	1	0	0	0	0	1	1
68	1	0	0	0	1	0	0
69	1	0	0	0	1	0	1
70	1	0	0	0	1	1	0
71	1	0	0	0	1	1	1
72	1	0	0	1	0	0	0
73	1	0	0	1	0	0	1
74	1	0	0	1	0	1	0
75	1	0	0	1	0	1	1
76	1	0	0	1	1	0	0
77	1	0	0	1	1	0	1
78	1	0	0	1	1	1	0
79	1	0	0	1	1	1	1
80	1	0	1	0	0	0	0
81	1	0	1	0	0	0	1
82	1	0	1	0	0	1	0
83	1	0	1	0	0	1	1
84	1	0	1	0	1	0	0
85	1	0	1	0	1	0	1
86	1	0	1	0	1	1	0
87	1	0	1	0	1	1	1
88	1	0	1	1	0	0	0
89	1	0	1	1	0	0	1
90	1	0	1	1	0	1	0
91	1	0	1	1	0	1	1
92	1	0	1	1	1	0	0
93	1	0	1	1	1	0	1
94	1	0	1	1	1	1	0
95	1	0	1	1	1	1	1
96	1	1	0	0	0	0	0
97	1	1	0	0	0	0	1
98	1	1	0	0	0	1	0

0 = Switch Off 1 = Switch On

APPENDIX B: CONTROLLER CIRCUIT BOARD

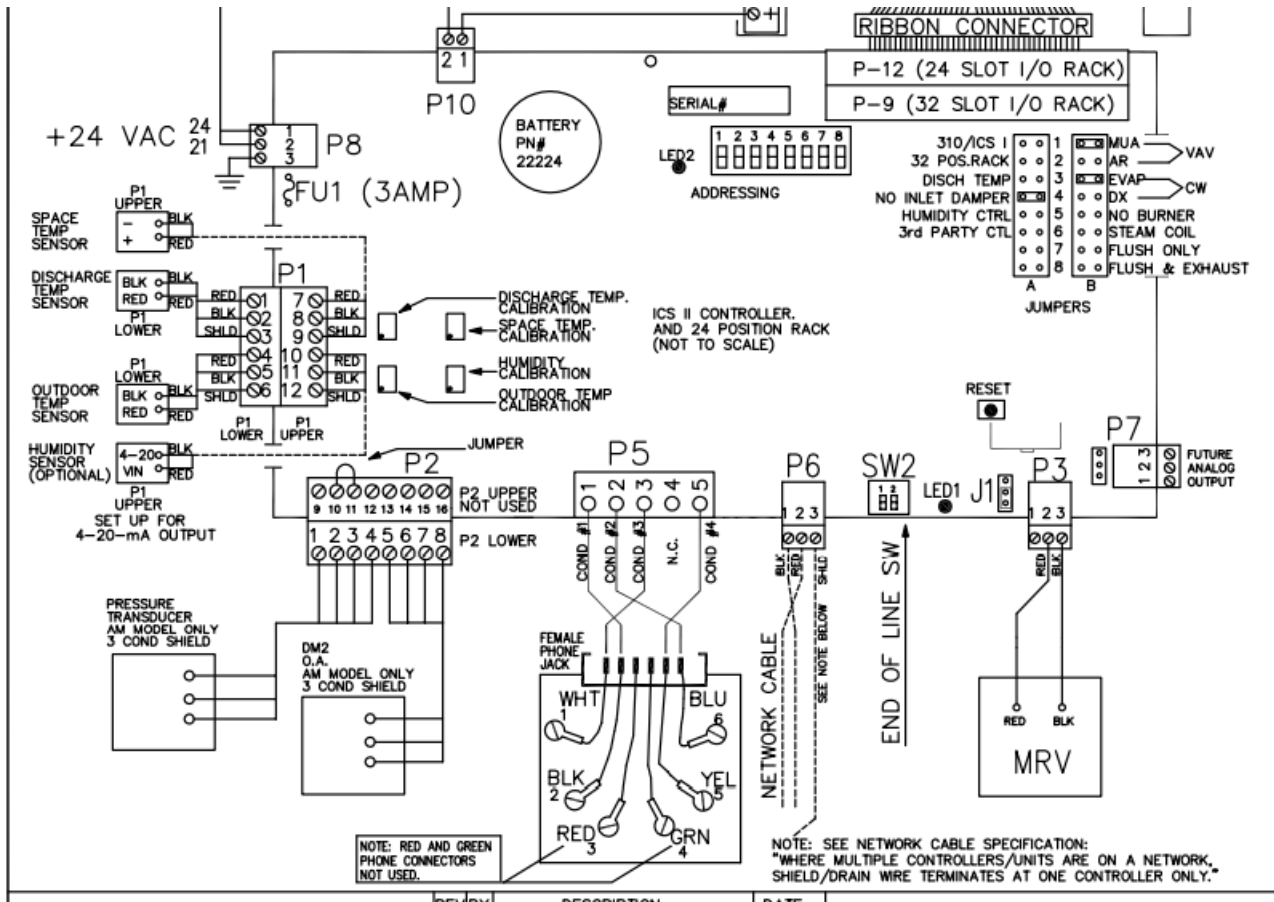

If a Controller must be replaced, all of the switches and jumpers on the new controller **must** be set to the same settings as the original controller. Refer to the following pages for a description and location of the Controller analog inputs and outputs, switches and jumper blocks.

- Address Switch: Each air handler has a unique address. Refer to APPENDIX A for more information on addressing.
- Controller Reset Switch. If the controller configuration or setup is changed, the reset switch should be depressed. This will cause a re-initialization of the controller.
- Jumper blocks A and B are used for configuring the controller for different options. The effect of each jumper setting is described on the following page.

JUMPER CONFIGURATION

Function:	P11 (B) jumper position	Jumper Setting / Effect			
AHU Type	1	<input checked="" type="checkbox"/>	<input type="checkbox"/>	<input checked="" type="checkbox"/>	<input type="checkbox"/>
	2	<input type="checkbox"/>	<input checked="" type="checkbox"/>	<input checked="" type="checkbox"/>	<input type="checkbox"/>
		MUA	AR	VAV	AM
Cooling Type	3	<input checked="" type="checkbox"/>	<input type="checkbox"/>	<input checked="" type="checkbox"/>	<input type="checkbox"/>
	4	<input type="checkbox"/>	<input checked="" type="checkbox"/>	<input checked="" type="checkbox"/>	<input type="checkbox"/>
		Evap	DX	ChWtr	Basic Vent
Burner Type	5	<input checked="" type="checkbox"/>	<input type="checkbox"/>	<input checked="" type="checkbox"/>	<input type="checkbox"/>
	6	<input type="checkbox"/>	<input checked="" type="checkbox"/>	<input checked="" type="checkbox"/>	<input type="checkbox"/>
		None	Htg. Coil	*** Gas	Gas
Flush/Exhaust Type	7	<input checked="" type="checkbox"/>	<input type="checkbox"/>	<input checked="" type="checkbox"/>	<input type="checkbox"/>
	8	<input type="checkbox"/>	<input checked="" type="checkbox"/>	<input checked="" type="checkbox"/>	<input type="checkbox"/>
		Flush only	Flush & Exhaust	Exhaust only	Neither
Function:	P13 (A) jumper position	Jumper Setting / Effect			
Controls Style	1	<input checked="" type="checkbox"/>	<input type="checkbox"/>		
		ICS I / 310	ICS II		
I/O Rack Size	2	<input checked="" type="checkbox"/>	<input type="checkbox"/>		
		32	24		
Future	3	<input checked="" type="checkbox"/>	<input type="checkbox"/>		
Underpressure Controls*	4	<input checked="" type="checkbox"/>	<input type="checkbox"/>		
		Active	Inactive		
Humidity Control**	5	<input checked="" type="checkbox"/>	<input type="checkbox"/>		
		Active	Inactive		
3rd Party On / Off	6	<input checked="" type="checkbox"/>	<input type="checkbox"/>		
		Active	Inactive		
Future	7	<input checked="" type="checkbox"/>	<input type="checkbox"/>		
Future	8	<input checked="" type="checkbox"/>	<input type="checkbox"/>		

Table 1

* When configured to make Underpressure controls active, the user-configurable output is not available for any other function than the Underpressure Alarm. If the air handler is an MUA or AR and has no inlet damper, a jumper shall be placed on position A4. This does not enable Underpressure control. It only configures the controller to not “look” for an inlet damper and limit switch.

** If jumpers for both B4 (DX cooling) and A5 (Humidity) are selected, the configuration used will be “DX Cooling with Reheat”. The normal Humidity control will NOT be active.

*** If B5 and B6 are selected, and the air handler is an AM or VAV or AR, the supply damper will be energized prior to the fan.

Analog (variable) Output Signal Specifications

P3 to Maxitrol MR212 valve.

1. 0 VDC to 24 VDC nominal
2. Dependent on unregulated voltage to op-amp
3. Dependent on line voltage
4. Modulation at $\pm 2\frac{1}{2}^{\circ}\text{F}$. of space temperature setpoint.
 - a. Output adjusted upward if discharge temperature is within $12\frac{1}{2}^{\circ}\text{F}$. of low discharge limit setpoint.
 - b. Output adjusted downward if discharge temperature is within $12\frac{1}{2}^{\circ}\text{F}$. of high discharge limit setpoint.

Analog (variable) Input Signal Specifications

Discharge Air Temperature Sensor

- a. +15 VDC at P1 pin #1 (lower) to red wire on sensor
- b. 0 VDC to +15 VDC at P1 pin #2 to black wire on sensor
- c. Ground at P1 pin #3

Outside Air Temperature Sensor

- a. +15 VDC at P1 pin #4 (lower) to red wire on sensor
- b. 0 VDC to +15 VDC at P1 pin #5 to black wire on sensor
- c. Ground at P1 pin #6

Space Temperature Sensor

- a. Shipped loose with the air handler
- b. +15 VDC at P1 pin #7 (upper) to red wire on sensor
- c. 0 VDC to +15 VDC at P1 pin #8 to black wire on sensor
- d. Ground at P1 pin #9

Humidity or Spare

- a. +15 VDC at P1 pin #10 (upper)
- b. 0 VDC to +15 VDC at P1 pin #11
- c. Ground at P1 pin #12

Space Pressure Sensor

- a. +15 VDC at P2 pin #1 (lower) to Vsup on sensor
- b. 0 VDC to +5 VDC at P2 pin #2 to Vout on sensor
- c. Ground at P2 pin #3 to Com on sensor
- d. Shield at P2 pin #4

Outside Air Damper Position

- a. feedback pot
- b. +5 VDC at P2 pin #5 (lower) to Y on mod motor
- c. 0 VDC to +5 VDC at P2 pin #6 to T on mod motor
- d. Ground at P2 pin #7 to G on mod motor
- e. Shield at P2 pin #8

Spare #1

- a. 0-5 VDC at P2 pin #9 (upper)
- b. P2 pin #10
- c. P2 pin #11
- d. Shield at P2 pin #12

Spare #2

- a. 0-5 VDC at P2 pin #13 (upper)
- b. P2 pin #14
- c. P2 pin #15
- d. Shield at P2 pin #16

APPENDIX C: TEMPERATURE SENSOR* PERFORMANCE

Temp (C)	Temp (F)	Volts**
-25	-13	2.480
-23.9	-11	2.491
-22.8	-9	2.502
-21.7	-7	2.513
-20.6	-5	2.524
-19.4	-3	2.536
-18.3	-1	2.547
-17.2	1	2.558
-16.1	3	2.569
-15.0	5	2.580
-13.9	7	2.591
-12.8	9	2.602
-11.7	11	2.613
-10.6	13	2.624
-9.4	15	2.636
-8.3	17	2.647
-7.2	19	2.658
-6.1	21	2.669
-5.0	23	2.680
-3.9	25	2.691
-2.8	27	2.702
-1.7	29	2.713
-0.6	31	2.724
0.6	33	2.736
1.7	35	2.747
2.8	37	2.758
3.9	39	2.769
5.0	41	2.780
6.1	43	2.791
7.2	45	2.802
8.3	47	2.813

Temp (C)	Temp (F)	Volts**
9.4	49	2.824
10.6	51	2.836
11.7	53	2.847
12.8	55	2.858
13.9	57	2.869
15.0	59	2.880
16.1	61	2.891
17.2	63	2.902
18.3	65	2.913
19.4	67	2.924
20.6	69	2.936
21.7	71	2.947
22.8	73	2.958
23.9	75	2.969
25.0	77	2.980
26.1	79	2.991
27.2	81	3.002
28.3	83	3.013
29.4	85	3.024
30.6	87	3.036
31.7	89	3.047
32.8	91	3.058
33.9	93	3.069
35.0	95	3.080
36.1	97	3.091
37.2	99	3.102
38.3	101	3.113
39.4	103	3.124
40.6	105	3.136
41.7	107	3.147
42.8	109	3.158

Temp (C)	Temp (F)	Volts**
43.9	111	3.169
45.0	113	3.180
46.1	115	3.191
47.2	117	3.202
48.3	119	3.213
49.4	121	3.224
50.6	123	3.236
51.7	125	3.247
52.8	127	3.258
53.9	129	3.269
55.0	131	3.280
56.1	133	3.291
57.2	135	3.302
58.3	137	3.313
59.4	139	3.324
60.6	141	3.336
61.7	143	3.347
62.8	145	3.358
63.9	147	3.369
65.0	149	3.380
66.1	151	3.391
67.2	153	3.402
68.3	155	3.413

* These temperature sensors are the AD592 integrated circuit type.

** Measure DC voltage across the 0-15VDC and ground terminals for either of the Discharge, Outdoor or Space temperature sensors.

NOTE: The purpose of this table is to assist a service technician in diagnosing sensor related problems. Without precision temperature measurement and a clear understanding of the accuracy specifications for these sensors, it will be impossible to exactly duplicate the table data. Normal service test equipment, however, used in conjunction with the table should indicate whether the sensor is operating properly.

APPENDIX D: TEMPERATURE SETPOINT RELATIONSHIPS

Occupied Period Setpoint	Typical Value
--------------------------	---------------

Maximum Discharge Temperature	95°F		
Occupied Space Cooling Setpoint Temperature	80°F	-----	3 - 25°F differential
Occupied Space Heating Setpoint Temperature	65°F	-----	
Minimum Heating Discharge Temperature	50°F		
Low Temperature Shutdown	40°F		

Unoccupied Period Setpoint	Typical Value
----------------------------	---------------

Maximum Discharge Temperature	95°F		
Unoccupied Unit Turnoff	60°F	-----	3 - 10 differential
Unoccupied Heating Space Setpoint Temperature	55°F	-----	
Minimum Discharge Temperature	50°F		
Low Temperature Shutdown	40°F		

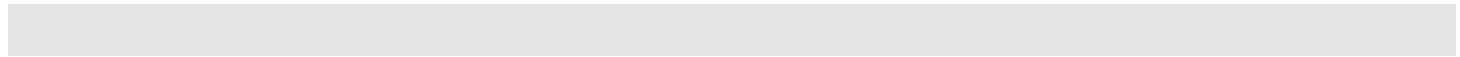

APPENDIX E: BINASC HOURLY LOG CONVERSION UTILITY

The Hourly Log information collected by the RAPID Intelligent Controls program is stored in a binary file which can be viewed via the Intelligent Controls' Display Log command.

This program provides a means to view the Hourly Log information independent of the Intelligent Controls program. It reads the binary Hourly Log file and then writes (most of) the information to an ASCII (text) file which can easily be imported to a word processing or spreadsheet program.

The BINASC program is used in the following way:

1. An Hourly Log file is named in a simple code that indicates the month for which it holds data. A couple examples are:

HL0194.dat	This file holds data for January of 1994.
HL0294.dat	This file holds data for February of 1994.

You'll find these files in the directory where the RAPID.EXE program resides. Normally this directory is named INTELCTL and is on the C: hard disk.

2. Copy the HLxxxx.DAT files which you're interested in to the same directory as the BINASC.EXE file. (We recommend just putting the BINASC.EXE file in the same directory as the RAPID.EXE and HLxxxx.DAT, so they're all together.)
3. Determine the name that you want to call the ASCII (text) version of the Hourly Log. (Any acceptable file name will do.)
4. Execute the BINASC program using the following format:

```
BINASC hlname newname
```

where hlname is the name of the Hourly Log you want to convert,
and newname is the name you want assigned to the Hourly Log text file.

As an example, if HL0194.DAT is the Hourly Log, you could type:

```
BINASC HL0194 DATA0194
```

5. After doing this, you would have a new text file named DATA0194.CSV which could easily be read by a word processing or spreadsheet program. BINASC.EXE assumes that the Hourly Log binary file has the suffix .DAT and adds the .CSV suffix automatically to the text file. Note that all of the data items in the text file will be delimited (separated) by commas.

APPENDIX F: INTELLIGENT HUMIDITY CONTROL

General:

Needs clarification re: "if enabled by jumper" and which output will be used for relief enable.

Steel warehouses cannot tolerate condensation on their products, since it can cause rust and render the product unusable. The RAPID Engineering Intelligent Humidity Control helps prevent condensation from occurring on the steel products stored in a building by raising temperature if the humidity rises above the humidity setpoint. If an auxiliary exhaust system is desired, the Humidity Control can stage burner and exhaust system operation so that they do not operate simultaneously or "fight" each other.

Sequence of operation:

The user defines a relative humidity setpoint (typically in the range of 70-80% RH). As the room relative humidity reaches that setpoint, the software causes the burner to ignite and warm the space. Raising the space temperature causes the relative humidity to drop and prevent condensation. The burner operates until the space relative humidity drops to 5% RH below the setpoint.

Any auxiliary exhaust system must be wired to the "Relief Enable" output of the RAPID Controller. The software will not energize this output until:

- the indoor temperature is greater than or equal to the "Relief Enable" setpoint and
- the indoor temperature is greater than or equal to the outdoor temperature. (This prevents introduction of outdoor air into the space when the space or product temperature may still be below the dewpoint of the outdoor air.) and
- the space relative humidity is 10% RH or more below the RH setpoint.

The auxiliary exhaust output will remain energized until:

- the indoor temperature falls below the "Relief Enable" setpoint or
- the indoor temperature falls 2F or more below the outdoor temperature or
- the space relative humidity rises to approximately 6% RH less than the RH setpoint.

The RAPID Intelligent Controls II software logs all principal operating parameters (including temperature and humidity) to the Network computer's hard disk hourly. In addition, data may be collected on any user-defined schedule (up to every 24 hours in one minute increments) and stored on the hard disk. All logs may be imported to any popular spreadsheet program for further analysis, graphing, etc.

Caution:

There is no way for the software to monitor conditions such as condensation which may occur on a roll of steel brought from the cold outdoors directly into the warm warehouse. The customer must manage these types of conditions so as to assure that the material warms to above the space dewpoint without condensation.

The Intelligent Humidity Control is active only in the Occupied mode, so the air handler must remain in that mode at all times during which humidity control is desired.

APPENDIX G: INTELLIGENT CONTROLS COMPUTER SPECIFICATION

Recommended Requirements:

- IBM 486/66 or true compatible with battery backed clock and ISA bus
- 8MB RAM
- 250 MB hard disk (minimum)
- Windows 95 OR DOS 6.2 or higher with Windows 3.1
- 3 1/2" 1.44 MB disk drive
- VGA Color monitor (color not normally used for a service technician laptop)
- 14400 bps (or faster) Hayes compatible modem configured for COM2.
(optional for service laptop)

Configuration of an Intelligent Controls PC

The RAPID Intelligent Controls network software allows use of any available COM port for normal communications. The communications adapter provided assumes that the connected COM port will be a 9 pin male plug. (The adapter provided by RAPID has a 9 pin female end.) If it's desired to use a 25 pin COM port, replace the RAPID-provided 25 pin female - 9 pin female adapter with a 25 pin female - 25 pin female adapter.

If a modem will be used for remote access to the Intelligent Controls program, the modem should use another COM port for communications than is used for Network communications. In addition, since COM ports #1 and #3 and COM ports #2 and #4 share interrupts, when the Network communications are conducted on #1 or #3, set up the modem for #2 or #4.

No two Interrupt values for active COM ports may be the same.

Notes :

A bus mouse is recommended and is required if a modem will be used for remote communications. This is because the serial mouse requires an interrupt, the modem requires another and the network communications require a third. Only two are available for simultaneous use.

RAPID recommends that a high quality surge protector be supplied with your network PC to increase it's reliability.

The software is supplied on 3.5" disks unless requested otherwise.

APPENDIX I: BURNER FIRING RATE CALIBRATION

High fire adjustments

In order to set the High Fire gas pressure correctly, three terms must be understood. They are:

- "No Fire" gas pressure: This is measured with a manometer connected to the gas piping downstream of the Modulating regulating Valve (normally at the High Gas Pressure Switch) with the fan ON and the burner and pilot OFF.
- "High Fire" gas pressure: This is measured with a manometer connected in the same place as for "No Fire" gas pressure, with the fan ON and the burner at "High Fire". The desired (correct) High Fire pressure is the SUM of the "Normal Manifold Pressure..." shown on the nameplate and the "No Fire" gas pressure.
- "Normal Manifold Pressure at Burner for Maximum Input Rating": This value is shown on the air handler nameplate. It is the DIFFERENCE between the "No Fire" and High Fire" gas pressures.

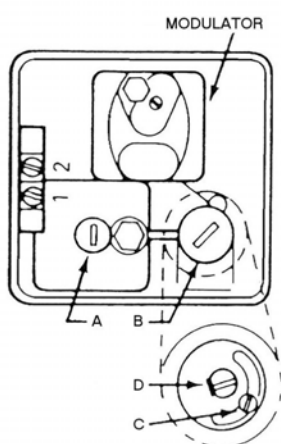

1. Force the air handler into High Fire by disconnecting P1 upper and lower connectors from the controller. This will simulate low space and discharge temperatures and will place approximately 24VDC on the Modulating Gas Valve coil. After five minutes, however, the air handler will change to the "Off" mode if P1 upper and lower connectors are not returned, since it "thinks" the discharge temperature is very cold and the air handler is unable to warm it.
2. Remove the seal cap (A) on the Regulator (which adjusts the High Fire Setting).
3. Turn the Regulator adjusting screw inside to achieve the desired "High Fire" gas pressure. (Clockwise rotation increases pressure.)

If the desired gas flow cannot be achieved (measured pressure value is too low), the regulator's spring may need to be replaced with one that has a different spring constant. The factory-furnished spring will accommodate outlet pressures in the range of 2-5" w.c.. Other springs can be supplied which accommodate outlet pressures between 1 - 22" w.c..

Example:

"Normal Manifold Pressure..." (from the factory nameplate)	8.0" w.c.
"No Fire" pressure (at High Gas Pressure Switch, fan ON)	-1.5" w.c.
Desired "High Fire" pressure (at High Gas Pressure Switch, fan ON, with the modulating / regulating valve forced into "High Fire").	6.5" w.c.

4. Replace the seal cap (A).
5. After testing, reconnect P1 upper and lower connectors to the controller.

Low fire adjustments

1. Force the air handler into Low Fire by disconnecting P3 from the controller.
2. Remove the seal cap (B) on the Low Fire Setting.
3. Loosen the lock screw (C) inside and then adjust the screw (D) until achieving the minimum practical continuous ribbon of flame. (Clockwise rotation reduces the minimum flow rate.)
4. Tighten the set screw (C).
5. Replace the seal cap (B).
6. After testing, reconnect P3 to the controller.

Note: Whenever high firing rate is adjusted, the low firing rate should be re-checked.

Highly negative manifold pressure adjustments

The MR212 is designed to operate with manifold pressure as low as -1.5" w.c.. When measuring the "No Fire" gas pressure, if measurement shows that the manifold pressure is lower than -1.5" w.c. (e.g., -2"), adjust as follows*:

1. Remove the seal cap on the Modulator, revealing two screws inside.
2. The screw which is centered on the Modulator is a cover for the plunger. If the plunger is suspected to be stuck, it can be removed from here. (It has nothing to do with the manifold pressure, however.)
3. The other screw (more toward the outer edge of the valve) adjusts the bias on the diaphragm. Adjust this screw until proper low fire is achieved, maintaining a continuous ribbon of flame.
5. Replace the seal cap.

* A manifold pressure this low is unusual and may be caused by clogged filters or other inlet obstructions. Before adjusting the Modulator, verify that there are no improper flow obstructions in the inlet.

SERVICE POWER SUPPLY
 480 V 3 PH 60 Hz
 33.0 FLA
 FEEDER PROTECTION
 SIZING BY OTHERS
 REF: N.E.C. TABLE 430-152

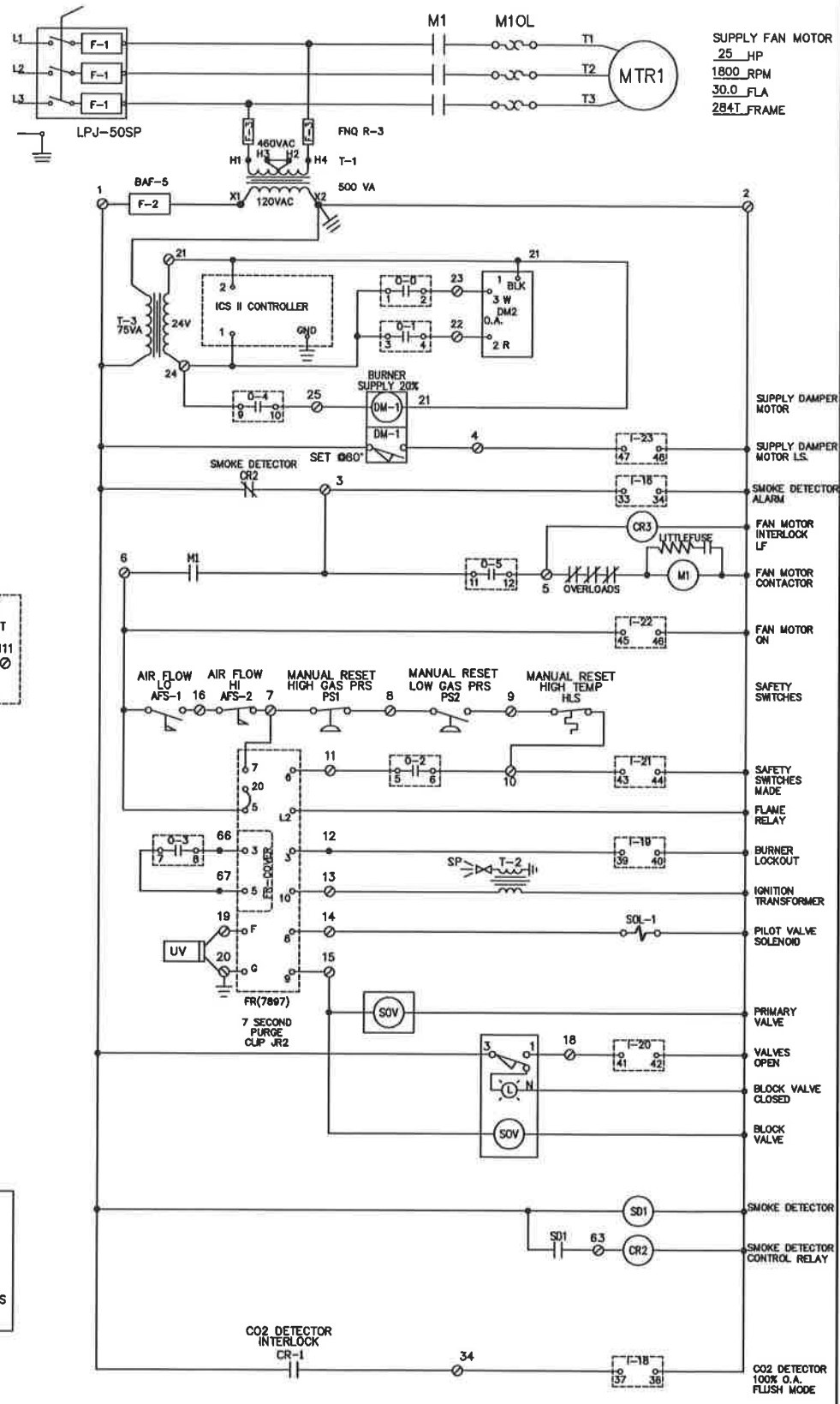

1
2
3
4
5
6
7
8
9
10
11
12
13
14
15
16
17
18
19
20
21
22
23
24
25
26
27
28
29
30
31
32
33
34
35

SUPPLY FAN MOTOR
 25_HP
 1800_RPM
 30.0_FLA
 284T_FRAME

SUPPLY DAMPER MOTOR
 SUPPLY DAMPER MOTOR LS
 SMOKE DETECTOR ALARM
 FAN MOTOR INTERLOCK LF
 FAN MOTOR CONTACTOR
 FAN MOTOR ON
 SAFETY SWITCHES
 SAFETY SWITCHES MADE
 FLAME RELAY
 BURNER LOCKOUT
 IGNITION TRANSFORMER
 PILOT VALVE SOLENOID
 PRIMARY VALVE
 VALVES OPEN
 BLOCK VALVE CLOSED
 BLOCK VALVE
 SMOKE DETECTOR
 SMOKE DETECTOR CONTROL RELAY
 CO2 DETECTOR 100% O.A. FLUSH MODE

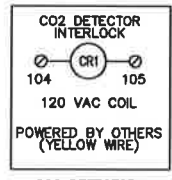
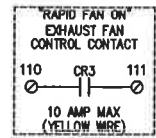

REV	BY	DESCRIPTION	DATE	Rapid ENGINEERING 1100 7 MILE RD. N.W. COMSTOCK PARK, MI 49321 1-616-784-6800	
2	JP	REVISED	11-4-08	DESCRIPTION: 4049 AM ELECTRICAL SCHEMATIC	
1	JP	RELEASE FOR PRODUCTION	10-6-08	DRAWN BY: JP	DATE: 10-6-08
Job: SPARTAN MOTORS			REV.	DWG NO.	
Tag #			FILE LOCATION: N:\ELEC\4000	WO#: 089384	SHEET: 1 OF 2

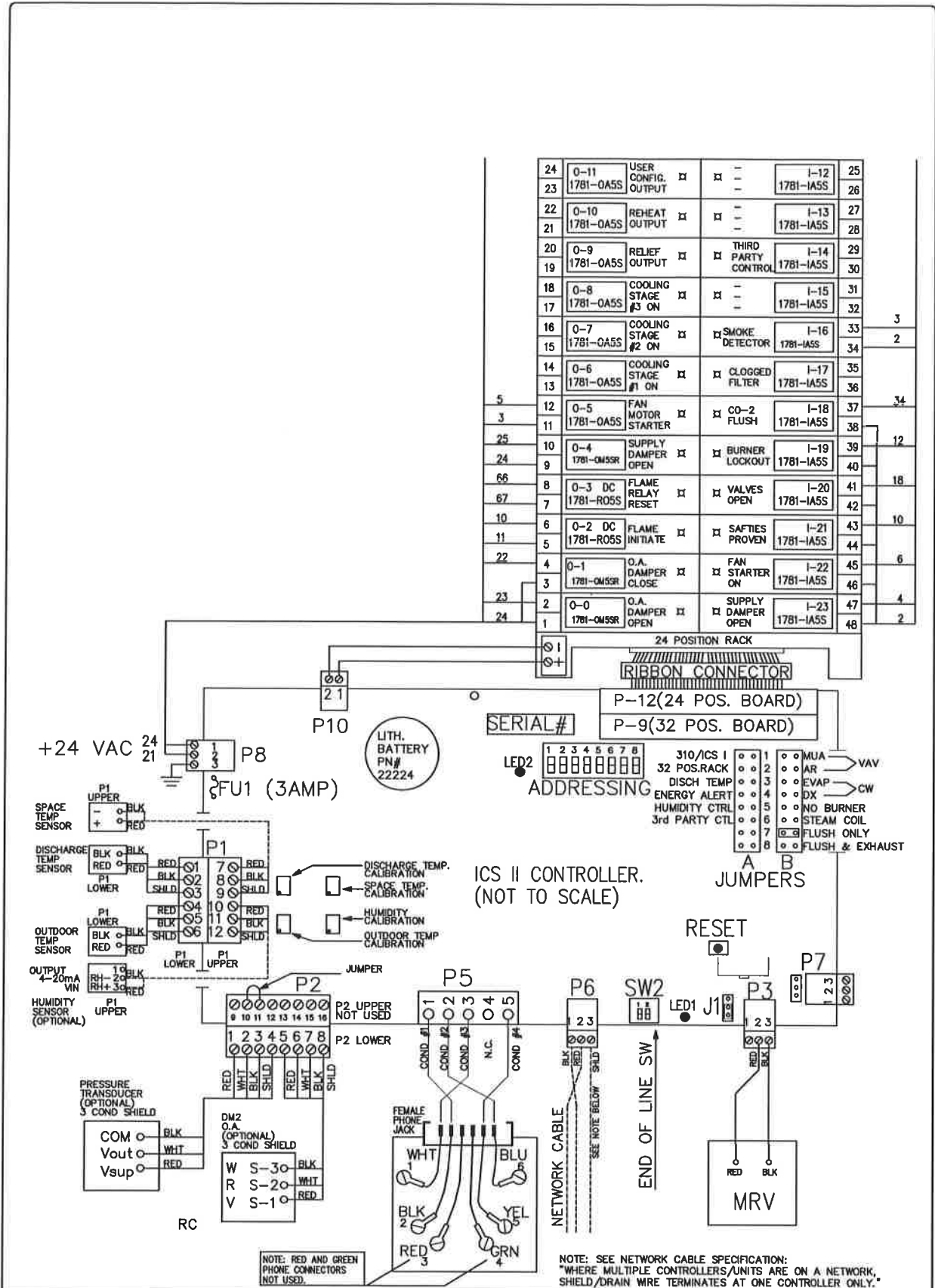

24	0-11	USER CONFIG. OUTPUT	1-12	25
23	1781-0A5S		1781-IA5S	26
22	0-10	REHEAT OUTPUT	1-13	27
21	1781-0A5S		1781-IA5S	28
20	0-9	RELIEF OUTPUT	1-14	29
19	1781-0A5S		1781-IA5S	30
18	0-8	COOLING STAGE #3 ON	1-15	31
17	1781-0A5S		1781-IA5S	32
16	0-7	COOLING STAGE #2 ON	1-16	33
15	1781-0A5S		1781-IA5S	34
14	0-6	COOLING STAGE #1 ON	1-17	35
13	1781-0A5S		1781-IA5S	36
12	0-5	FAN MOTOR STARTER	1-18	37
11	1781-0A5S		1781-IA5S	38
10	0-4	SUPPLY DAMPER OPEN	1-19	39
9	1781-0M5SR		1781-IA5S	40
8	0-3 DC	FLAME RELAY RESET	1-20	41
7	1781-RO5S		1781-IA5S	42
6	0-2 DC	FLAME INITIATE	1-21	43
5	1781-RO5S		1781-IA5S	44
4	0-1	O.A. DAMPER CLOSE	1-22	45
3	1781-0M5SR		1781-IA5S	46
2	0-0	O.A. DAMPER OPEN	1-23	47
1	1781-0M5SR		1781-IA5S	48

REV	BY	DESCRIPTION	DATE
2	JP	REVISED	11-4-08
1	JP	RELEASE FOR PRODUCTION	10-6-08

FILE LOCATION: N:\ELEC\4000

Rapid ENGINEERING
 1100 7 MILE RD. N.W.
 COMSTOCK PARK, MI 49321
 1-616-784-6800

DESCRIPTION: 4049 AM CONNECTION DIAGRAM
 DRAWN BY: JP DATE: 10-6-08 REV. DWG NO.
 WO#: 089384 SHEET: 2 OF 2 50020900

Job: SPARTAN MOTORS
 Tag #

SERVICE POWER SUPPLY
 480 V 3 PH 60 Hz
 38.0 FLA
 FEEDER PROTECTION SIZING BY OTHERS
 REF: N.E.C. TABLE 430-152

SUPPLY FAN MOTOR
 30 HP
 1800 RPM
 35.0 FLA
 286T FRAME

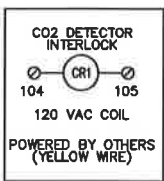
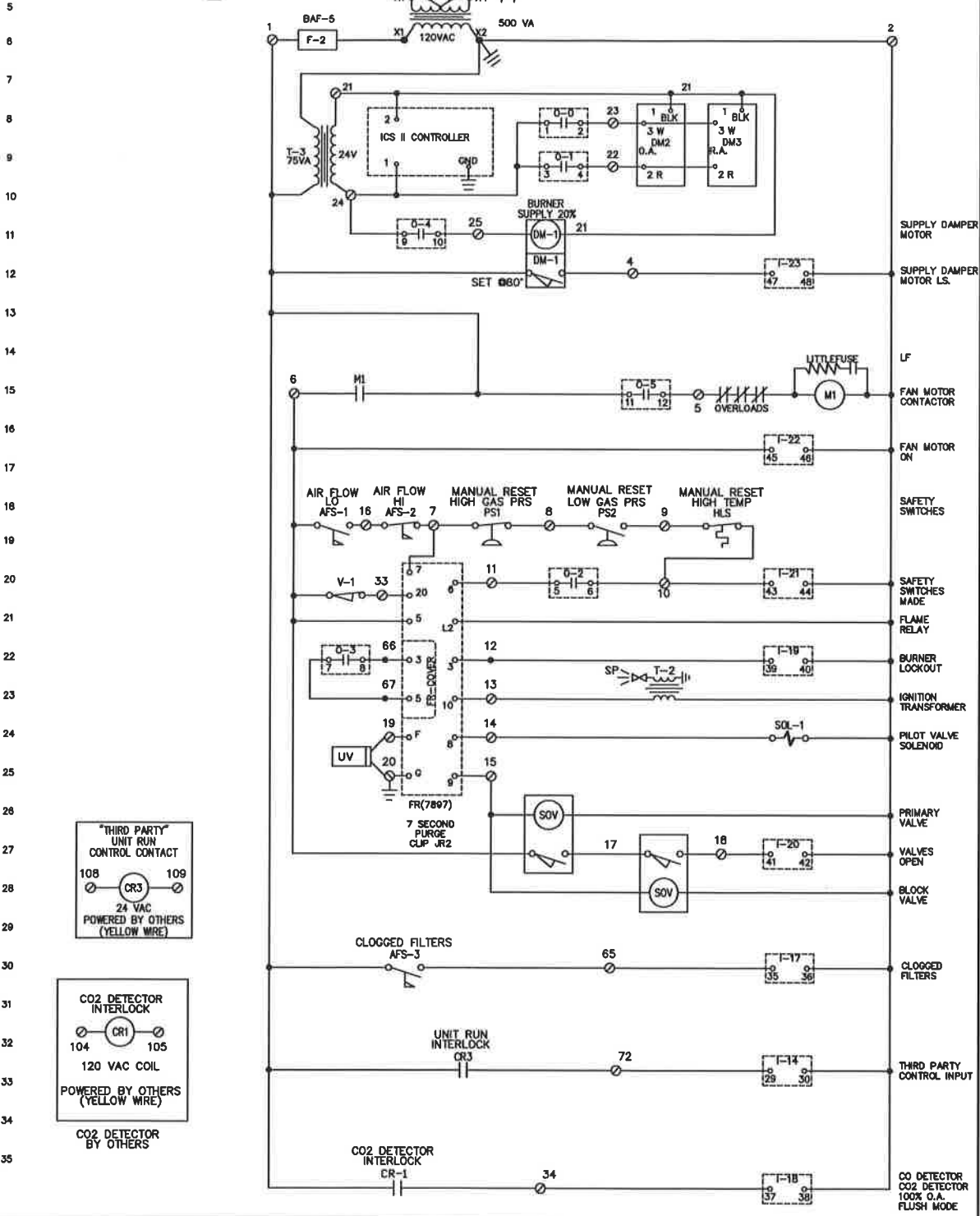

CO2 DETECTOR BY OTHERS

REV	BY	DESCRIPTION	DATE
2	JP	REVISED	0-23-08
1	JP	RELEASE FOR PRODUCTION	8-28-08



RAPID ENGINEERING
 1100 7 MILE RD. N.W.
 COMSTOCK PARK, MI
 49321
 1-616-784-6800

Job: WELL CONCRETE

Tag #

DESCRIPTION: 4066 AM	ELECTRICAL SCHEMATIC
DRAWN BY: JP	DATE: 8-28-08
REV. DWG NO.	
FILE LOCATION: N:\ELEC\4000	WO#: 089365-366 SHEET: 1 OF 2
	50020884

24	0-11	USER CONFIG. OUTPUT	1781-0A5S	1-12	1781-IA5S
23	0-10	REHEAT OUTPUT	1781-0A5S	1-13	1781-IA5S
22	0-9	RELIEF OUTPUT	1781-0A5S	1-14	1781-IA5S
21	0-8	COOLING STAGE #3 ON	1781-0A5S	1-15	1781-IA5S
20	0-7	COOLING STAGE #2 ON	1781-0A5S	1-16	1781-IA5S
19	0-6	COOLING STAGE #1 ON	1781-0A5S	1-17	1781-IA5S
18	0-5	FAN MOTOR STARTER	1781-0A5S	1-18	1781-IA5S
17	0-4	SUPPLY DAMPER OPEN	1781-0MSR	1-19	1781-IA5S
16	0-3 DC	FLAME RELAY RESET	1781-RO5S	1-20	1781-IA5S
15	0-2 DC	FLAME INITIATE	1781-RO5S	1-21	1781-IA5S
14	0-1	O.A. DAMPER CLOSE	1781-0MSR	1-22	1781-IA5S
13	0-0	O.A. DAMPER OPEN	1781-0MSR	1-23	1781-IA5S
12				1-24	1781-IA5S
11					
10					
9					
8					
7					
6					
5					
4					
3					
2					
1					

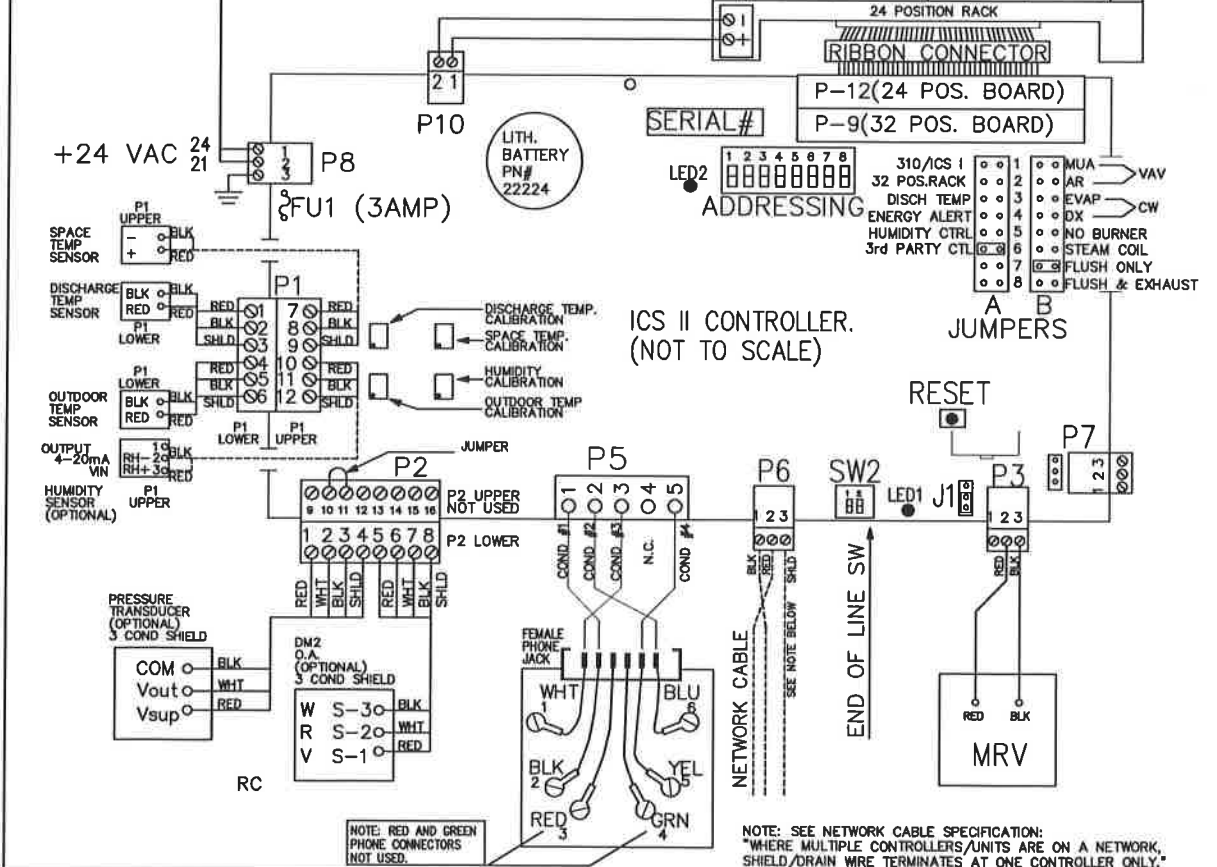

REV	BY	DESCRIPTION	DATE
2	JP	REVISED	9-23-08
1	JP	RELEASE FOR PRODUCTION	8-28-08

Job: WELL CONCRETE	Tag #	FILE LOCATION: N:\ELEC\4000	DESCRIPTION: 4066 AM CONNECTION DIAGRAM	DATE: 8-28-08	REV. DWG NO.
			WO#: 089365-366	SHEET: 2 OF 2	50020884

Rapid ENGINEERING
1100 7 MILE RD. N.W.
COMSTOCK PARK, MI 49321
1-616-784-6800

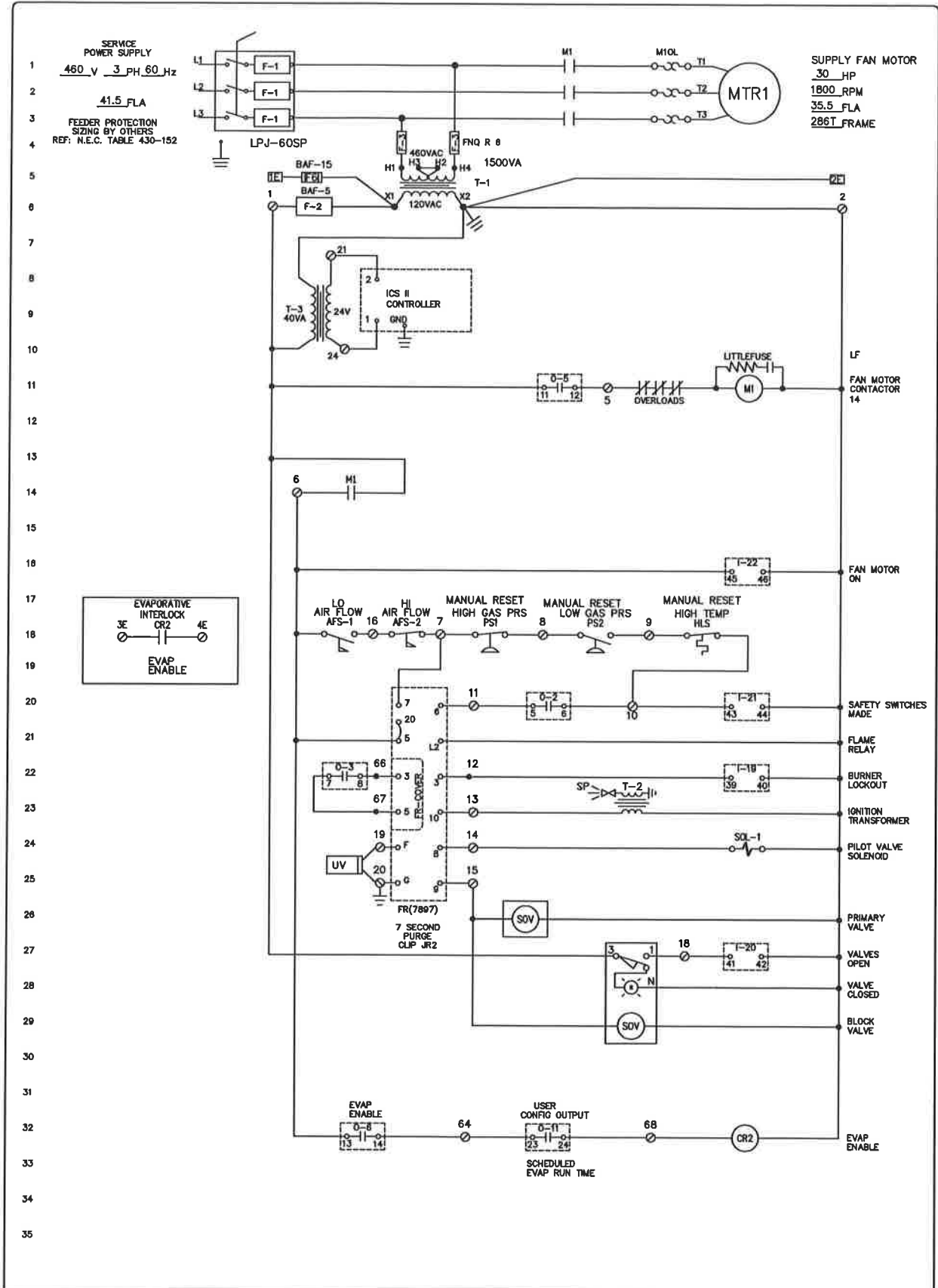

SERVICE
POWER SUPPLY
480_V 3_PH 60_Hz
41.5_FLA
FEEDER PROTECTION
SIZING BY OTHERS
REF: N.E.C. TABLE 430-152

SUPPLY FAN MOTOR
30_HP
1800_RPM
35.5_FLA
286T_FRAME

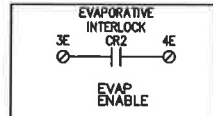

REV	BY	DESCRIPTION	DATE	 RAPID ENGINEERING 1100 7 MILE RD. N.W. COMSTOCK PARK, MI 49321 1-616-784-6800		
2	JP	AS BUILT	9-25-08	DESCRIPTION: 4054 MUA ELECTRICAL SCHEMATIC		
1	JP	RELEASE FOR PRODUCTION	9-3-08	DRAWN BY: JP	DATE: 9-3-08	REV. DWG NO.
FILE LOCATION: N:\ELEC\4000				WO#: 089355-356	SHEET: 1 OF 3	50020886

Job: INTERFACE FLOORING
Tag #

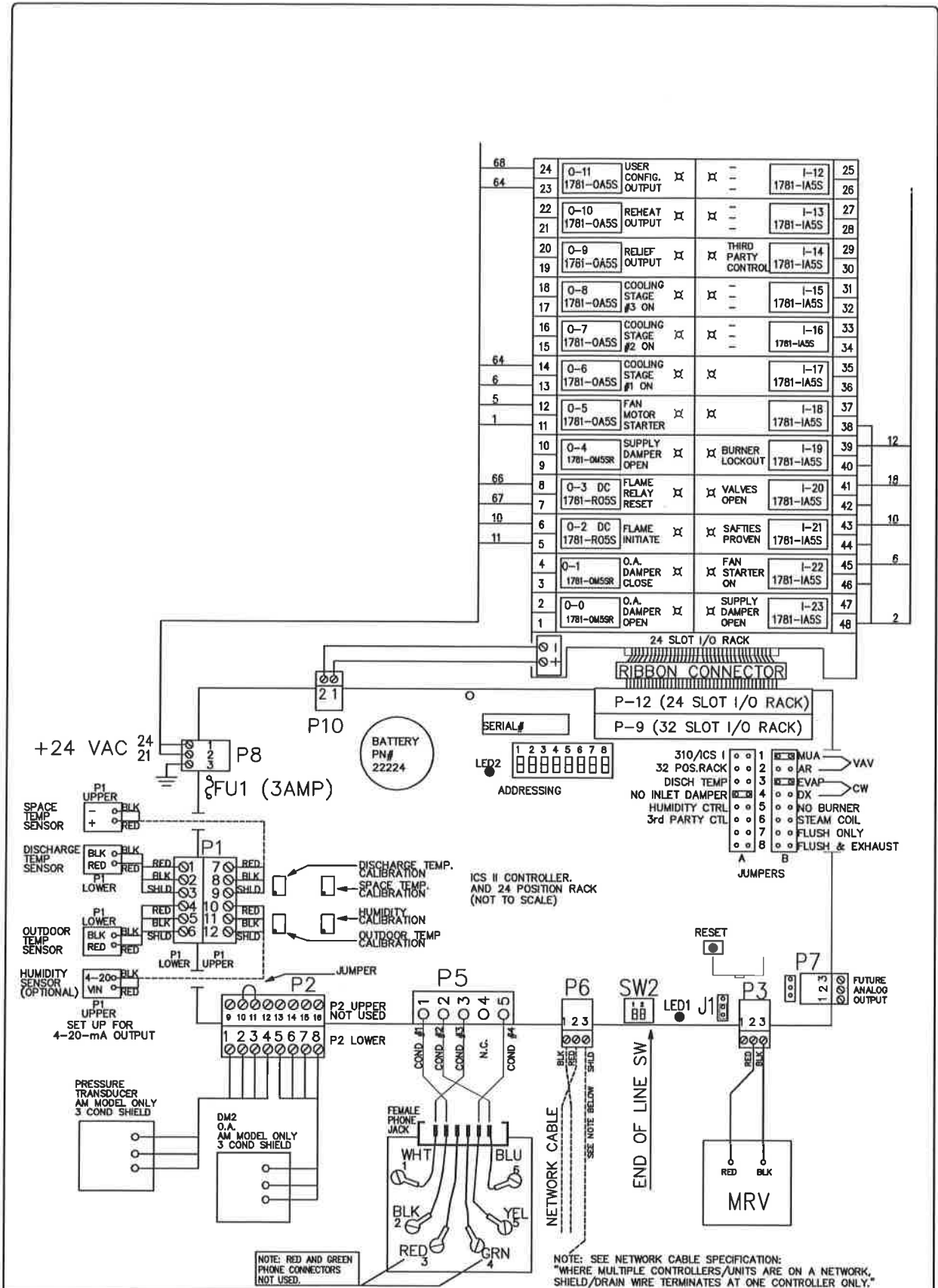

REV	BY	DESCRIPTION	DATE
2	JP	AS BUILT	9-25-08
1	JP	RELEASE FOR PRODUCTION	9-3-08

Job: INTERFACE FLOORING	Tag #	N: \ELEC\4000	DESCRIPTION: 4054 MUA CONNECTION DIAGRAM
			DRAWN BY: JP DATE: 9-3-08 REV. DWG NO.
			WO#: 089355-356 SHEET: 2 OF 3 50020886

